

### Features

- Working voltage: 2.4V~5.0V
- 7 tempo options
- 2 "CHA" envelopes
- Normal or octave higher option
- 4 operation modes
- Extremely few external components
- Drive an 8Ω speaker through an NPN transistor
- 3-pin TO-92 or 16 DIP/SOP package

### General Description

The HT3820 series are single-chip 128 note melody generators implemented in CMOS technology. It can play a melody of 128 notes by trigger input or automatically when power is on. Customers' melody sources are programmed by changing a masking layer during device fabrication.

The HT3820 can play various musical effects: Chord, Broken Chord, "CHA" sound accompaniment. The mask option can be made to accom-

modate various melodies, tempos, envelopes, and "CHA" sound duration (refer to the functional description).

The output driver can drive an 8Ω speaker through an external NPN transistor. The HT3820 is an ultra-miniature device and almost no external components are required for normal applications.

### Pin Assignment

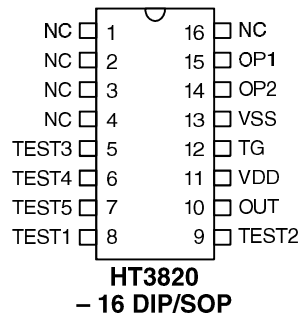
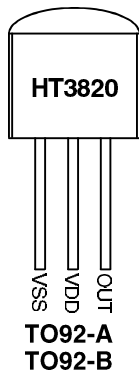

IC No.	Package Form	Bond Option	Function
HT3820 Series	TO92-A	TG pad is bonded to VSS pin	Play once
	TO92-B	TG, OP1 & OP2 pads are bonded to VSS pin	Play repeatedly
	16 DIP/SOP	—	—

**Block Diagram**

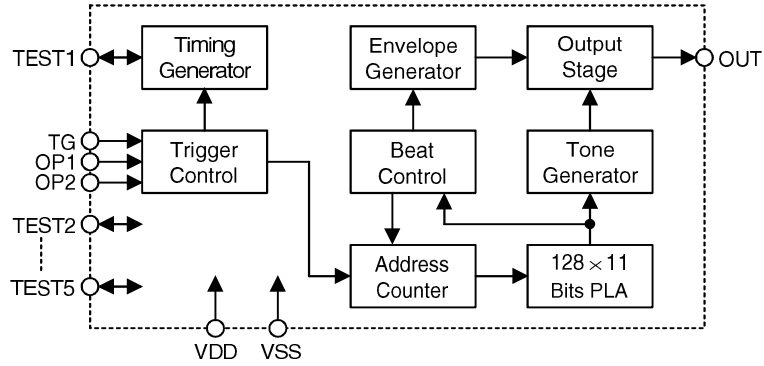

**Pad Coordinates**

Unit: mil

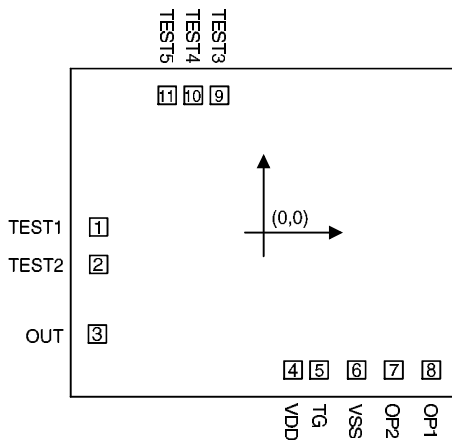

Pad No.	X	Y	Pad No.	X	Y
1	-41.84	1.44	7	33.13	-34.89
2	-41.84	-8.03	8	42.61	-34.89
3	-42.18	-25.8	9	-11.16	34.89
4	7.54	-34.89	10	-17.79	34.89
5	14.17	-34.89	11	-24.42	34.89
6	23.65	-34.89			

Chip size: 97 × 81 (mil)<sup>2</sup>

\* The IC substrate should be connected to VDD in the PCB layout artwork.

**Pad Description**

Pad No.	Pad Name	I/O	Internal Connection	Description
1	TEST1	I/O	CMOS	For IC test only. This pad can output the system operation frequency or supply external clock for system operation.
2	TEST2	I/O	CMOS	For IC test only
3	OUT	O	CMOS	Melody signal output. It's a PWM signal format.
4	VDD	I	—	Power supply (positive)
5	TG	I	CMOS Pull-High	Trigger input, active low
6	VSS	I	—	Power supply (ground)
7, 8	OP2, OP1	I	CMOS	Operation and trigger mode selection. Refer to the functional description for details.
9~11	TEST3~TEST5	I/O	CMOS	For IC test only

**Absolute Maximum Ratings**

Supply Voltage ..... -0.3V to 5.5V      Storage Temperature ..... -50°C to 125°C  
 Input Voltage .....  $V_{SS}-0.3V$  to  $V_{DD}+0.3V$       Operating Temperature ..... -20°C to 75°C

**Electrical Characteristics**

(Ta=25°C)

Symbol	Parameter	Test Condition		Min.	Typ.	Max.	Unit
		V <sub>DD</sub>	Condition				
V <sub>DD</sub>	Operation Voltage	—	—	2.4	—	5	V
I <sub>STB1</sub>	Stand-by Current	3V	No load (when TG is open)	—	1	2	μA
		5V		—	2	5	μA
I <sub>STB2</sub>	Stand-by Current	3V	No load (for TO-92 package, TG is connected to VSS)	—	4	8	μA
		5V		—	10	21	μA
I <sub>DD</sub>	Operation Current	3V	No load (average)	—	130	220	μA
		5V		—	300	500	μA
I <sub>IL</sub>	Input Low Current (for TG pad)	3V	V <sub>IL</sub> =0V	—	3	6	μA
		5V		—	8	16	μA
I <sub>OH</sub>	Output Source Current	3V	V <sub>OH</sub> =0.9V <sub>DD</sub>	-2	-3.6	—	mA
		5V		-5	-8.6	—	mA
I <sub>OL</sub>	Output Sink Current	3V	V <sub>OL</sub> =0.1V <sub>DD</sub>	3	5	—	mA
		5V		5	8.2	—	mA
F <sub>OSC</sub>	System Frequency	3V	—	—	256	—	KHz

## Function Description

### Pad (Pin) option

There are 4 operating modes to be selected by changing the statuses of OP1 and OP2. The possible combinations of OP1 and OP2 are shown as follows:

OP1	OP2	Operation Mode
VSS	VSS	Level hold trigger and play repeatedly
VSS	Open	Level hold trigger but play once
Open	VSS	One shot trigger and retriggerable
Open	Open	One shot trigger and non-retriggerable

Notice if the user wants to change the operation mode, the states of OP1 and OP2 have to be changed first, followed by turning the power supply on.

### Mask option

The HT3820 provides several options for selection but only one mask layer can be changed.

Tempo Speed (beat per minute)	469,234,156,117,94,78,67
"CHA" Sound Envelope	(1) 1/2 beat (2) 1/4 beat
Channel Output (2 channel)	(1) Chord (synchronous play) (2) Broken chord (asynchronous play)
Octave Selection	(1) Normal (2) Higher octave

**Timing Diagram**

**Level hold trigger & play repeatedly**

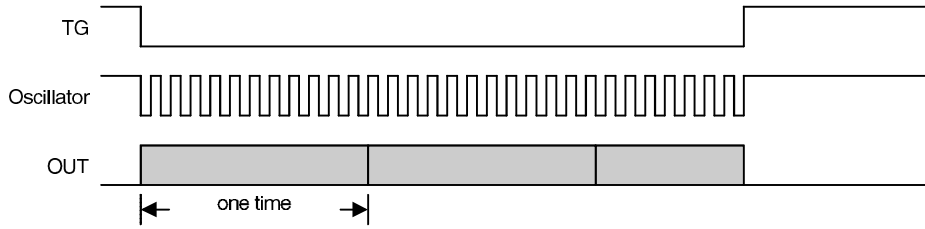

**Level hold trigger but play once**

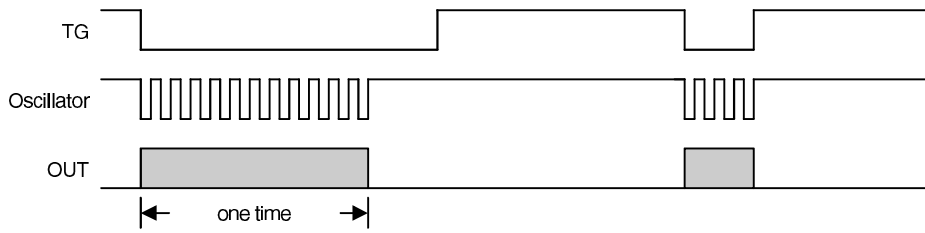

**One shot trigger & retriggerable**

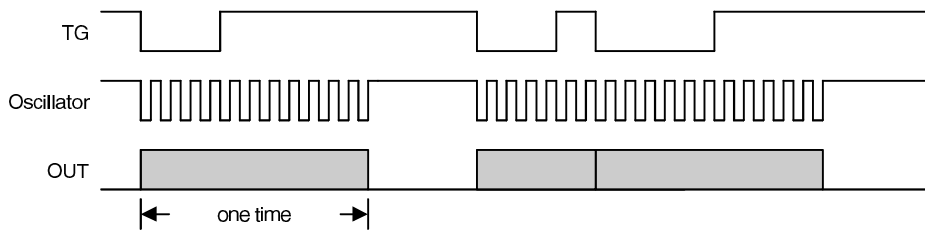

**One shot trigger & non-retriggerable**

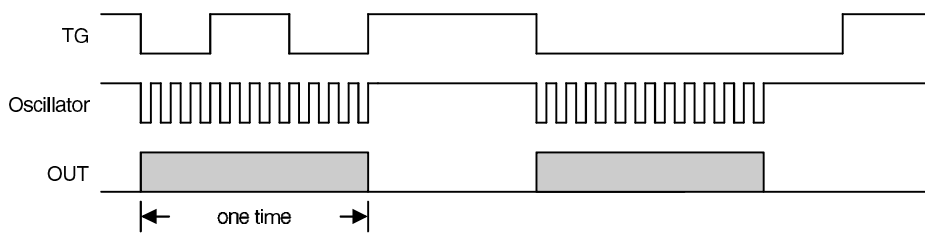

**HT3820 Series Selection Table**

<b>IC No.</b>	<b>Song Name</b>
HT3820A	Happy birthday
HT3820B	Ding-dong
HT3820C	The tweleve days of christmas
HT3820D	We wish you a merry X'mas
HT3820F	Jingle bell
HT3820G	For Elise
HT3820H	It is a small world
HT3820I	Home sweet home
HT3820J	Rock a bye baby
HT3820K	You are my sunshine
HT3820L	Wedding march
HT3820N	Love story
HT3820P	Changing Partner
HT3820Q	Hey Jude
HT3820R	Love is blue
HT3820S	Yesterday
HT3820T	Love me tender
HT3820U	My way
HT3820V	Jesus love me & The first noel
HT3820W	London bridge is falling down & The train is running fast
HT3820X	You light up my life
HT3820Y	Oh! Susanna
HT3820Z	Santa Claus is coming to town
HT3821A	When the saints go marching in
HT3821B	Macarena

### Application Circuits

Chip from

- Normal operation

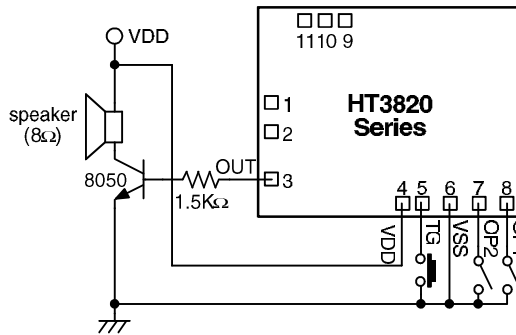

OP1	OP2	Trigger & operation mode
VSS	VSS	Level hold trigger and play repeatedly
VSS	Open	Level hold trigger but play once
Open	VSS	One shot trigger and retriggerable
Open	Open	One shot trigger and non-retriggerable

\* Notice if the states of OP1 & OP2 are changed, the power must be turned on again.

\* Note: The IC substrate should be connected to VDD in the PCB layout artwork.

- Power-on trigger

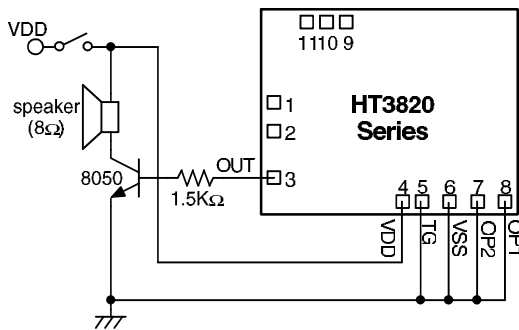

\* Level hold trigger and play repeatedly

\* Note: The IC substrate should be connected to VDD in the PCB layout artwork.

• Cds trigger application

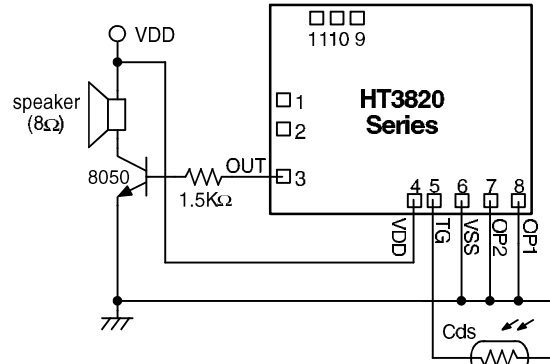

\* Level hold trigger and play repeatedly

\* Note: The IC substrate should be connected to VDD in the PCB layout artwork.

Package form

• 16 DIP/SOP, Normal operation

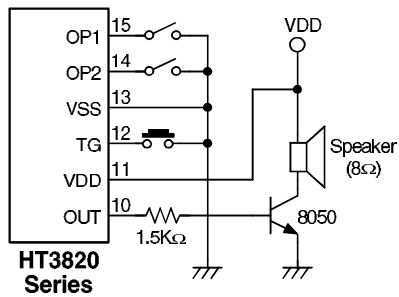

OP1	OP2	Trigger & operation mode
VSS	VSS	Level hold trigger and play repeatedly
VSS	Open	Level hold trigger but play once
Open	VSS	One shot trigger and retriggerable
Open	Open	One shot trigger and non-retriggerable

\* Notice if the states of OP1 & OP2 are changed, the power must be turned on again.

\* As for the "Power On trigger" and "Cds trigger" applications, refer to the chip form applications.

• TO-92, Power On trigger

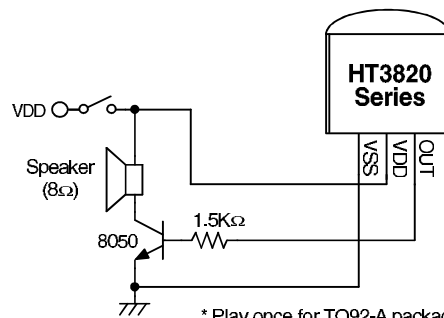

\* Play once for TO92-A package.  
Play repeatedly for TO92-B package.